



# Stackable Poly Tanks

The competition can't stack up to Snyder!

Cubetainer™



Slimtainer™



## Stackable Storage & Dispensing Systems

Providing Bulk Storage Tanks, Stands, and Containment Solutions for Motor Oil, Lubricants, Hydraulic Fluids, ATF, Antifreeze & DEF



Made in the USA

[www.snydernet.com](http://www.snydernet.com) • 888-422-8683



# Cubetainer™

*Stackable Storage & Dispensing Systems*

Snyder Industries is a recognized world leader in the design and manufacturing of highly engineered durable rotationally molded tanks used in a wide variety of industries for over 55 years!

Snyder's Cubetainer™ product line offers cost effective fluid storage solutions for Auto Service Shops, Quick Lube Stores, Fleet Operations and a variety of other industries.

## **Eliminate Hassles of 55 Gallon Drums**

- Messy clutter from drum storage.
- Unused product in each "empty" drum.
- Potential contamination from outdoor drum storage.
- Down-time moving 55 gallon drums.
- Potential injury and workers comp claims from moving awkward drums.

## **Buy in Bulk: Reduce Your Total Fluid Expenses**

A one-time, cost-effective investment will store multiple Class IIIB fluids such as motor oils, lubricants, hydraulic fluids, ATF, Antifreeze, DEF and many other fluids. A refillable bulk storage system also reduces waste from packaged goods.

## **Optimize Valuable Shop Space**

Our space saving stackable fluid systems can open up valuable floor space to allow for additional revenue producing shop work space or the expansion of the number of service bays.

## **Flexibility to Move Fluids Throughout Your Shop or Forklift Tanks into Trucks**

Convert a stationary system into a portable storage system for point-of-use dispensing with either caster wheels or the addition of a forklift/pallet jack pallet base.

## **Secondary Containment**

Provides a clean and safe barrier between the tank and the environment for EPA and SPCC Compliance. Primary tanks combined with secondary containment provide a clean, space saving solution to meet SPCC guidelines and 40 CFR 264.175 requiring 110% capacity of a single primary tank within the containment.



60 gallon tank.



80 gallon tank.



120 gallon tank.



180 gallon tank.



260 gallon tank.

# DEPENDABLE, VERSATILE AND DURABLE SPACE-SAVING STACKABLE STORAGE & DISPENSING SYSTEMS

- Constructed from Virgin High Density FDA compliant Polyethylene Resin.
- Standard Footprint with all sizes making them stackable in any combination – No conversion brackets needed which add cost!
- Convenient center fill.
- Translucent tank and molded in and inked level markers allow for visual level inspection without the need for external site gauges.

2" top opening for pump or vent application.

1" opening for desiccant breather or remote fill.

6 molded-in brass inserts allow for side mount pump plate to be attached.

Molded-in brass 1" NPT bushing at drain openings.

Optional pallet is forklift & pallet jack accessible and compatible with all sizes and stand configurations, including competitive products.



Stacking compatible with competitive products.

Interlocking top and bottom ridges for secure stacking.

Convenient 2" center fill opening.

Molded-in and inked site gauge showing both gallons and liters, and semi-transparent material, eliminates the need for external site gauges.

Part No. Brass Inserts	Gallon Capacity	Dimensions
103200N95401	60	36" x 36" x 17 1/2"
1032100N95401	80	36" x 36" x 21 3/4"
1032200N95401	120	36" x 36" x 30 1/2"
1032300N95401	180	36" x 36" x 44"
1032400N95401	260	36" x 36" x 57 1/4"

## Options / Accessories



Durable powder-coated steel stands in a variety of leg heights



316SS Spring Valve



Desiccant Air Breather Filter



Gravity Feed Accessories



Drip Tray Kit



Pump System Accessories

# CUBETAINER™ LUBE PUMP KIT OPTIONS

Snyder's Cubetainer™ pump systems provide a versatile and convenient option for dispensing from the tank directly to your equipment. Pump packages include 3:1 pneumatic pump, 50 foot hose reel, non-preset dispensing meter, air filter regulator and all the necessary mounting brackets and hardware.



**Side Mount Package**  
P/N 34702302



**Top Mount Package**  
P/N 34702303



**Wall Mount Package**  
P/N 3702304

**Pump Kits Include:**

- 3:1 Pump.
- 50' Hose Reel.
- Electronic non-preset meter dispensing nozzle.
- Air filter regulator.
- Brackets & hardware for attachment to tank.

# CUBETAINER™ MOBILE BASE OPTIONS

Snyder offers mobile base options that includes 4" caster and 10" pneumatic wheel bases that allow you to roll the Cubetainer™ to your work space. In addition, Snyder offers a corrosion resistant polyethylene fork-lift base that allows you to move the Cubetainer™ or load them into trucks as well as stack on top of other Cubetainers™.



**4" Caster Wheel Kit**



**10" Pneumatic Wheel Kit**  
*(Limited to 120 gallon size or smaller)*



**Forklift/Pallet-Jack stackable pallet base**

# CUBETAINER™ CONTAINMENT OPTIONS



Part No.	Description
1032500N97801 (Can be used on 60-180 gallon sizes)	203 Gal. Containment (52" x 58" x 20" H)
1014700M97301 (For 260 gallon size without stand)	288 Gal. Containment (44" x 48" x 42" H)
1007900N97801 (For 260 gallon size with stand)	390 Gal. Containment (62" x 76" x 28" H)

# Cubetainer™ Gravity Feed Systems

*Complete stackable systems that can be ordered with one simple part number.*

Cubetainer™ Gravity Feed Systems include stackable tanks, stand with 24" legs, drip tray kit, 316SS spring valves and the gravity feed hose accessory package to complete all connections. Additional stacked combinations can be configured as long as combined stacked height is 82" or less from the stand base (not including the stand legs) to the top of the tank.



**60/60/60**  
#1033200N95401  
36" L x 36" W x 70" H



**60/60/60/60**  
#1033600N95401  
36" L x 36" W x 83" H



**60/60/120**  
#1033300N95401  
36" L x 36" W x 83" H



**60/60/180**  
#1033400N95401  
36" L x 36" W x 95" H



**80/80**  
#1032700N95401  
36" L x 36" W x 65" H



**80/80/80**  
#1033500N95401  
36" L x 36" W x 83" H



**80/80/80/80**  
#1034400N95401  
36" L x 36" W x 100" H



**80/120**  
#1032800N95401  
36" L x 36" W x 74" H



**120/120**  
#1032900N95401  
36" L x 36" W x 83" H



**120/120/120**  
#1034300N95401  
36" L x 36" W x 108" H



**120/180**  
#1033000N95401  
36" L x 36" W x 95" H



**180/180**  
#1033100N95401  
36" L x 36" W x 108" H



# Slimtainer™

*Narrow Design for Tighter Spaces*

Slimtainers™ are designed with space in mind. These stackable space saving systems maximize valuable floor space in shops where a narrower footprint is required. Like our stackable Cubetainer systems, the Slimtainers™ will provide safe and efficient storage for a variety of bulk Class IIIB fluids including oils, lubricants, hydraulic fluids, ATF and anti-freeze, all within the narrowest tank footprint on the market! Stackable tanks are cleaner and more reliable than traditional oil drums and allow you to buy in bulk to reduce your total fluid expenses!

- **Narrow 23" deep footprint** - Allows for use in tight spaces along bays or between bays.
- **Dispensing outlets on the front and both ends of the tank** - Provides versatility for a wide range of installation options.
- **When stacked two high, top fill is at 84"** - Complies with maximum fill height for many oil suppliers.
- **Translucent tank with molded-in and inked level markers** - Allow for visual level inspection without the need for external site gauges.
- **Constructed from high density FDA compliant polyethylene resin.**
- **Available wall anchor kits** - for added stability and security.
- **Optional 25" wide 110% containment** - complies with EPA/SPCC.



120/120 Slimtainer™ with Stand/  
Containment



120/120 Slimtainer™ with Stand & Drip Tray



120 with Stand & Drip Tray



120 with Stand & Containment

**PATENT NO. 10,370,146**

# Snyder Slimtainer™

Interlocking top and bottom points for secure stacking.

Convenient 2" center fill opening.

2" top opening for pump or vent application.

Three Molded-in brass 1" NPT Bushings (one on each end and front).

Molded internal pass through holes to suppress bulging and add strength and stability.

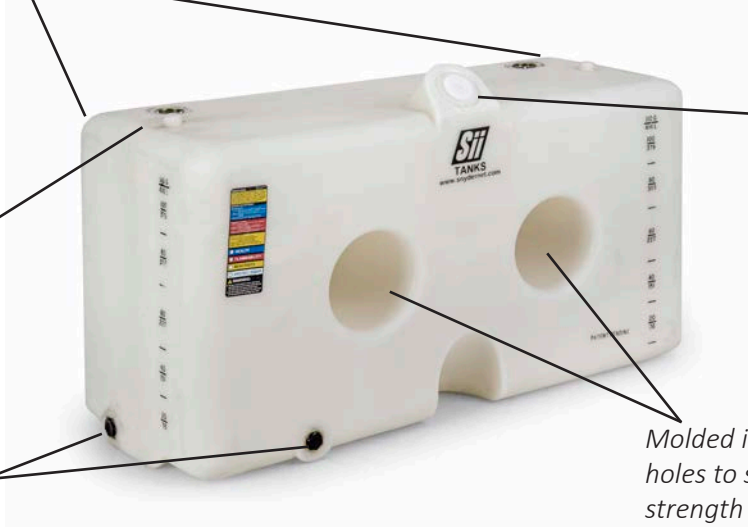

Part No. Brass Inserts	Gallon Capacity	Dimensions
1035500N95401	120 Slimtainer™	54" x 22" x 32"
1035500N95402	120 Slimtainer™ with Stand/Drip Tray	64.5" x 23" x 56"
1035700N95402	120/120 Slimtainer™ with Stand/Drip Tray	64.5" x 23" x 84"
1035500N95403	120 Slimtainer™ with Stand/Containment	74" x 24.5" x 56"
1035700N95403	120/120 Slimtainer™ with Stand/Containment	74" x 24.5" x 84"

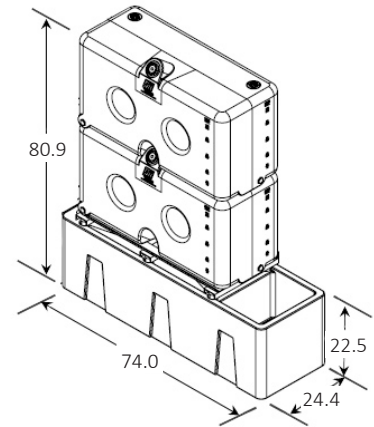
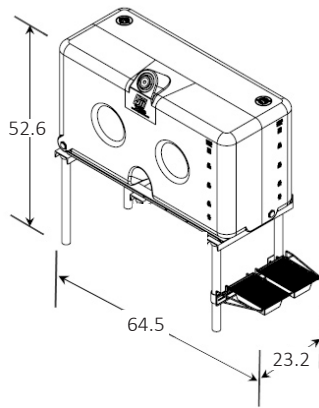
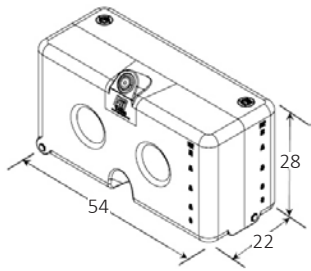

## Options / Accessories



Durable powder-coated steel stands in a variety of leg heights



Gravity Feed Systems



316SS Spring Valve



Drip Tray Kit

# Snyder Offers Many Solutions in Fluid Handling



Stationary tanks- 8 to 16,500 gal.

## **BULK STORAGE & PROCESSING TANKS**

For larger stationary applications, Snyder offers the industry's broadest range of tanks – from 8 to 16,500 gallons – in shapes that meet your specific needs. To match your special function requirements, we also market a complete line of accessories, such as stands, seismic tie-downs, ladders, fittings, gaskets, sight gauges, heat tracing and insulation.



Double Wall tanks- 35 to 12,500 gal.

## **DOUBLE WALL CONTAINMENT TANK SYSTEMS**

For outdoor applications or when larger capacity is needed Snyder offers double wall tank-in-a-tank containment systems in one space-saving unit ranging in size from 35 to 12,500 gallons. The double-wall construction is completely enclosed so that external matter such as rainwater, snow or debris is prevented from collecting in the outer containment.



Transportation containers- 60 to 550 gal.

## **UN/DOT-APPROVED IBCs - STEEL, PLASTIC, & COMPOSITE**

Snyder intermediate bulk containers (IBCs) are durable, corrosion-resistant and economical. These long-term, reusable containers are ideal for the transportation of both hazardous and non-hazardous liquid materials, including containers for viscous materials, like greases.



## **USED OIL COLLECTION TANK SYSTEMS**

Unique tank-in-a-tank space saving containment system provides 120% containment of tank capacity to comply with EPA standards for waste oil storage containers CFR 40-279.22. Tanks are maintenance free and won't rust, chip or dent and are weather resistant for outdoor use. Lockable lid design provides outdoor security.



## **DRUM CONTAINMENT & PALLET PRODUCTS**

Drum containment systems for one, two or four drums. Super heavy duty Drum Pallets with drum locators and safety locking systems for stacking. All products are molded of chemical resistant polyethylene and feature a reinforced design and one piece seamless construction for long lasting, heavy use.

## **ONE SOURCE DOES IT ALL**

*Whether you are a manufacturer or distributor, Snyder Industries can help you improve the function, economics and performance of your company's bulk handling systems.*

6940 "O" Street, Suite 100 • Lincoln, Nebraska 68510 • 402-467-5221 • FAX: 402-465-1220 • sales@snydernet.com  
Other manufacturing locations: Marked Tree, Arkansas • Chowchilla, California • Philippi, West Virginia • Mancelona, MI • Bensenville, Illinois • West Chicago, Illinois

[www.snydernet.com](http://www.snydernet.com)

Revised 10/2019